

Standard Multi-Position Coaxial Switches



RLC Electronics' Standard Multi-Position Coaxial Switch line provides extremely high reliability, long life and outstanding electrical performance characteristics by utilizing high density

packaging. The "Multi-Position" electrical characteristics features extremely low insertion loss and VSWR over the entire DC-12.4GHz range, while maintaining high isolation.

Specifications

S1-2-3-4-5-6-7

RF Positions	3	4	5	6
Switch Type:	SP-3T	SP-4T	SP-5T	SP-6T
Frequency Range:(GHz)	DC-12.4	DC-12.4	DC-12.4	DC-12.4
Insertion Loss (Max dB)				
DC-7 GHz	0.30	0.30	0.30	0.30
7.0-12.4 GHz	0.60	0.60	0.60	0.60
VSWR (Max)				
DC-7 GHz	1.30	1.30	1.30	1.30
7.0-12.4 GHz	1.60	1.60	1.60	1.60
Isolation (dB) (Min)	55	55	55	55

Power Rating, RF Cold Switching: See page 5.

Impedance: 50 Ohms/75 Ohms.*

Operating Power 25°C:

(Failsafe): 12Vdc at 270 ma nom.

28Vdc at 190 ma nom. 115Vac at 50 m nom.

(Latching) 28 Vdc at 310 mA nom. 12 Vdc at 550 mA nom.

Cutthroat circuitry (standard), recovery time 100ms nom.

Connectors, RF: N, SMA, TNC, BNC* Female.

Connectors, Power: Feed through solder lugs.

Life: 1,000,000 operations.

Switching Time: 20 mS Max. Failsafe 125ms latching.

Weight: 20oz.

Environmental Conditions: MIL-S-3928

Operating Mode: Manual, failsafe or latching

Switching Sequence: Break before make.

*BNC not recommended for use above 1GHz

*75 ohm up to 3 GHz.

To designate the switch desired use:

- | | |
|--|---|
| (1) "M" for Manual, "R" for Remote. | (5) "I" for indicators if desired. |
| (2) "3", "4", "5" or "6" throw operation | (6) "L" for Latching cutthroat if desired |
| (3) "N", "T" for TNC, "B" for BNC or "R" for SMA type connectors | (7) "TL" for TTL Driver if desired |
| (4) "A" for 115 Vac, "D" for 28 Vdc or "H" for 12 Vdc. | |

Example: SR-6-N-D-I-L is a remote, 6 position, N connector, 28 Vdc with indicators latching cutthroat switch. 50 ohms for 75 ohms SR75-

Outline Drawing

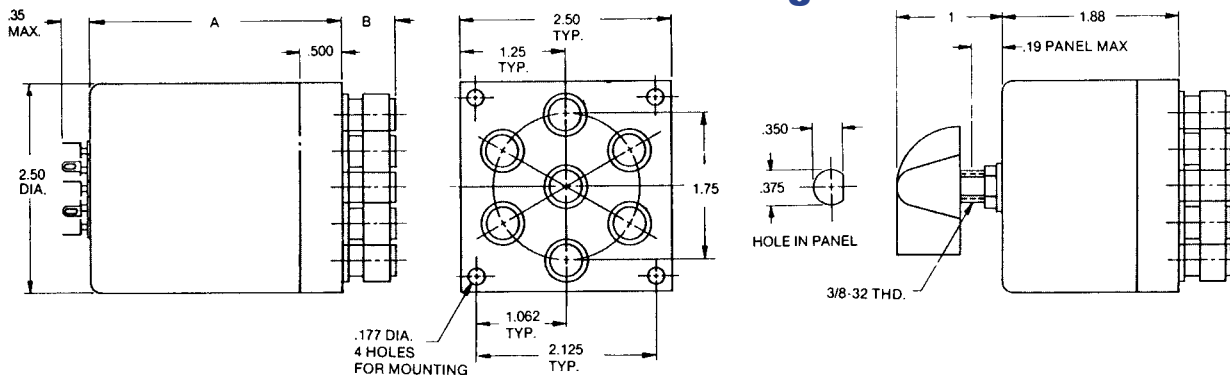

MODEL	A	
	FAILSAFE	LATCHING
SR-**-D	3.06	3.72
SR-**-D-I	3.72	3.72
SR-**-A	3.72	4.34
SR-**-A-I	3.72	4.34

CONN	B
N	.54
BNC/TNC	.48
SMA	.44

Tolerances unless otherwise specified are: .xx, ±.02; .xxx, ±.005.



RLC ELECTRONICS, INC.

83 Radio Circle, Mount Kisco, New York 10549 • Telephone: 914-241-1334 • Fax: 914-241-1753
e-mail: sales@rlcelectronics.com • www.rlcelectronics.com